



**"Charleston/Arlington"**  
**Raised Panel**  
**Interior Doors**

# Raised Panel Doors

## "Charleston/Arlington" General Information

### "CHARLESTON"

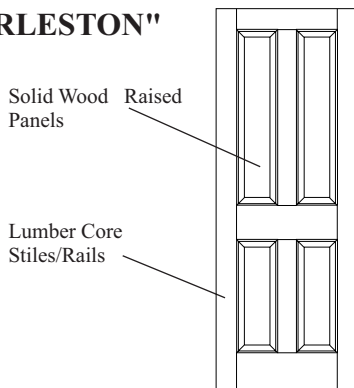

### "ARLINGTON"

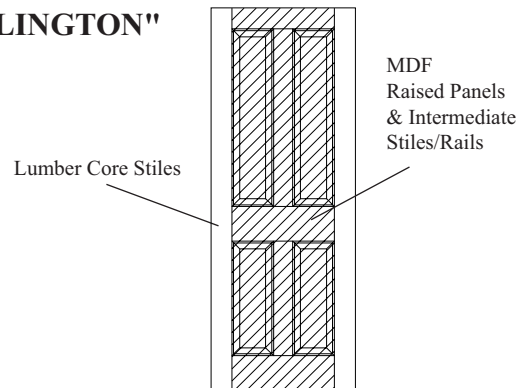

**CHARLESTON:** The "Charleston" collection includes a series of door styles that are constructed with solid wood raised panels and lumber core stiles/rails. Charleston doors are available in both 1 3/8" and 1 3/4" thicknesses. 1 3/4" thick doors can be ordered as 'A' Series (3/4" thick panels) or as 'B' Series (1 1/8" thick panels).

**ARLINGTON:** The "Arlington" collection includes a series of door styles that are constructed for painted applications with lumber core stiles and MDF center panels and intermediate stiles/rails. *Arlington doors include a "Base" primer at no additional charge* (see page 39 for a description of "Base" primer and "Premium" finish options). Arlington doors are available in both 1 3/8" and 1 3/4" thicknesses. 1 3/4" thick doors can be ordered as 'A' Series (3/4" thick panels) or as 'B' Series (1 1/8" thick panels). Arlington doors are a perfect complement to Charleston doors and vary only in construction.

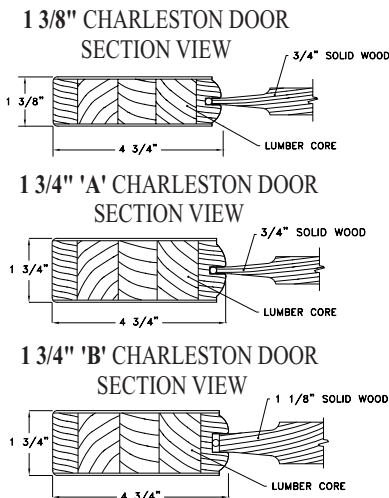

Series 'B' Doors are available in Red Oak, Poplar, Maple, Cherry, Mahogany, Knotty Alder, White Oak, Character Oak and Character Cherry

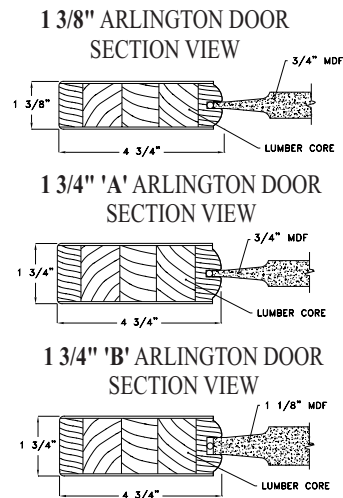

### OPTIONS AVAILABILITY

	1 3/8"	1 3/4" A	1 3/4" B
Woods	ALL	ALL	N/A in Birch & Hickory
Arch Options	ALL	ALL	ALL
Profile Options	Std. Hip Dbl. Hip Cove/Bead	Std. Hip Dbl. Hip Cove/Bead	Std. Hip Dbl. Hip Cove/Bead

See page 6 for more information on Profile Options.

### OPTIONS AVAILABILITY

	1 3/8"	1 3/4" A	1 3/4" B
Woods	PAINTABLE/MDF		
Arch Options	ALL	ALL	ALL
Profile Options	Std. Hip Dbl. Hip Cove/Bead	Std. Hip Dbl. Hip Cove/Bead	Std. Hip Dbl. Hip Cove/Bead

See page 6 for more information on Profile Options.

# Raised Panel Doors

## "Charleston/Arlington" General Information

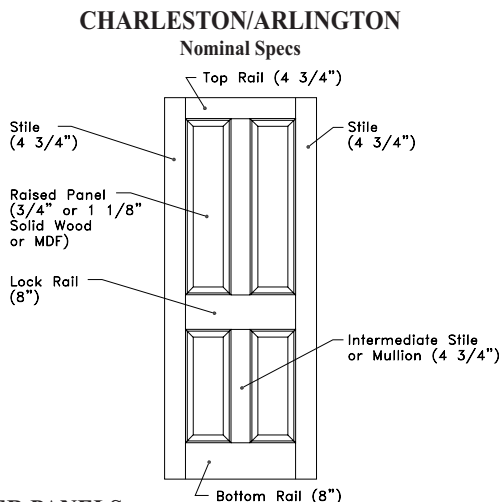

### CENTER PANELS:

**Raised Panels:** Raised panels are a nominal 3/4" or 1 1/8" thick staved solid wood or MDF. The panel profile is carved according to the customer's "profile option" selection.

### ARCH OPTIONS

Charleston & Arlington door styles are available with a variety of Arch options.

#### ROMAN ARCH (20 SERIES)

Doors specified with a Roman Arch are designated as a "20 Series" arch on the order form. The door has a square (flat) top and the top panels are carved with a Roman Arch. (i.e. C4-11, 20 Series)  
*A "Continuous Arch option is available for 20 Series arch double doors, by-pass and double pocket doors at no charge. Specify "Continuous Arch 20 Series" when placing your door order.*

See page 31.

#### CATHEDRAL ARCH (30 SERIES)

Doors specified with a Cathedral Arch are designated as a "30 Series" arch on the order form. The door has a square (flat) top and the top panels are carved with a Cathedral Arch.

(i.e. C4-11, 30 Series)

#### ARCH TOP - EYEBROW (40 SERIES)

Doors specified with an Eyebrow Arch Top are designated as a "40 Series" arch on the order form. The door has an "eyebrow" radius at the top of the door and the top panels are carved with a Roman Arch. **Arch Top doors can be pre-hung in Solid Wood Jamb's only.** Casing is available on a special-order/custom quote basis. (i.e. C4-11, 40 Series)

*Other Arch/Radius options are available on a custom quote basis.*

*Contact Customer Service with specific information to receive a price quote.*

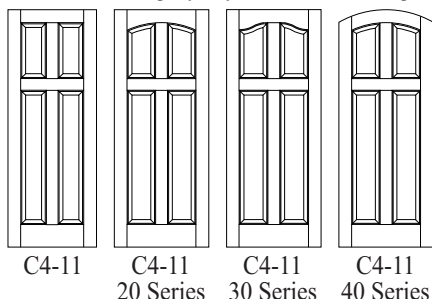

### PROFILE OPTIONS

Charleston and Arlington doors are available with a choice of "Profile Options". A Profile Option designates the decorative profile of the "sticking" (inside edge of the stile/rail) *and* the raised panel. A Profile Option must be specified for Charleston and Arlington door styles.

#### "STANDARD HIP" PROFILE

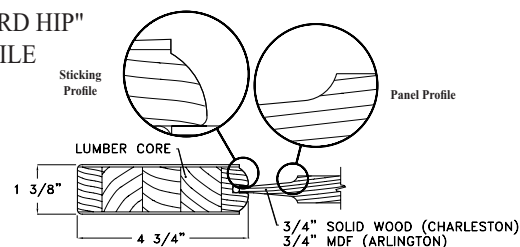

#### "DOUBLE HIP" PROFILE

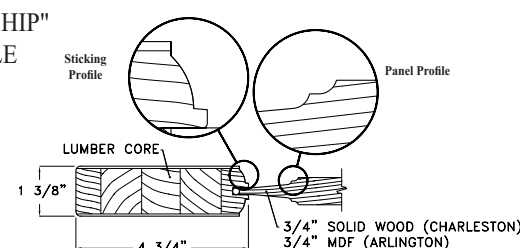

#### "COVE & BEAD" PROFILE

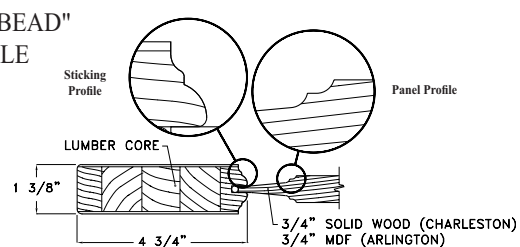

#### "BASE" PRIMER (Arlington):

Panels are individually hand-sanded before the door is assembled. Once the door is assembled, the entire door is carefully machine-sanded and then hand-sanded. The entire door then receives one coat of catalyzed conversion varnish primer. Stiles and rails are then coat-sanded prior to packaging and delivery. Please note that additional sanding is required before jobsite finishing. *(Arlington doors automatically include a "Base" primed finish at no charge. Pre-hung doors include a "Base" primed jamb.)*

#### "PREMIUM" PRIMER (Arlington):

Panels are individually hand-sanded and then primed before the door is assembled. Once the door is assembled, the entire door is carefully machine-sanded and then hand-sanded. Joints are filled and sanded flush. The first coat of catalyzed conversion varnish is applied and then the entire door is hand-sanded again. A second coat of primer is applied and then the door is completely hand-sanded before packaging and delivery. Please note that the door must be lightly scuff-sanded prior to jobsite finishing to ensure good adhesion of the final finish coat(s).

*Enamel finishes are also available from the factory.*

# Raised Panel Doors

## CHARLESTON/ARLINGTON INTERIOR DOORS

C1-10\*  
A1-10

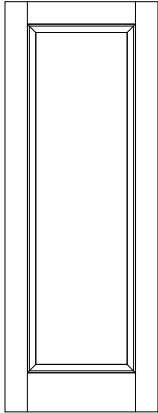

C2-10\*  
A2-10

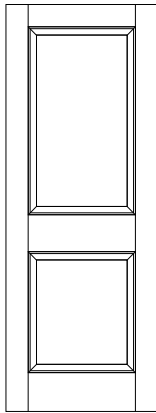

C2-11\*  
A2-11

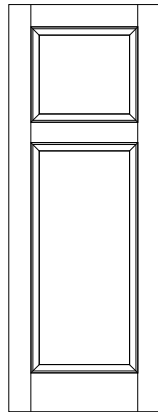

C2-12  
A2-12

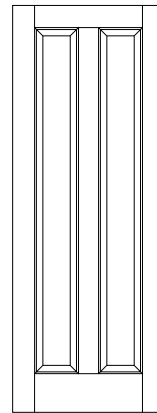

C2-13\*  
A2-13

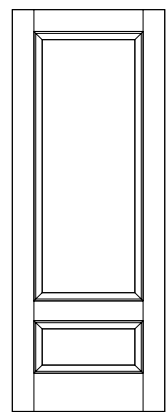

C3-10\*  
A3-10

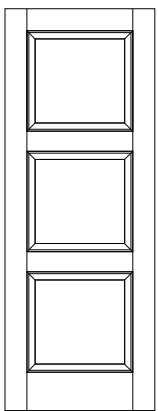

C3-11\*  
A3-11

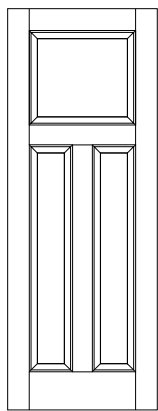

C3-12  
A3-12

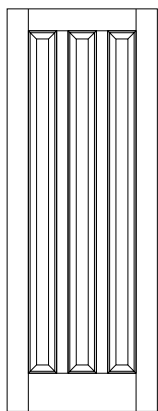

C3-13\*  
A3-13

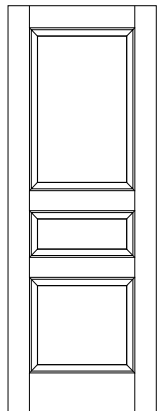

C3-14\*  
A3-14

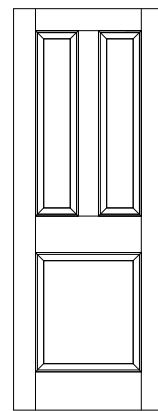

C3-15\*  
A3-15

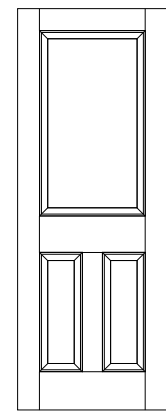

\* Charleston doors with full width panels (vertical grain) are especially susceptible to expansion and contraction with uncontrolled levels of humidity. The Woodharbor warranty covers all manufacturer's defects, however, expansion/contraction concerns as a result of moisture are not covered under the warranty.

### STANDARD SIZES (Nominal)

Door Heights: 6/8, 7/0, 8/0

Passage & Pocket Doors: 1/0, 1/3, 1/4, 1/6, 1/8, 1/10, 2/0, 2/2, 2/4, 2/6, 2/8, 2/10, 3/0

Double & Pocket Doors: 2/6, 2/8, 3/0, 4/0, 4/8, 5/0, 5/4, 6/0

Bi-Fold Doors: 2/0, 2/6, 3/0, 4/0, 5/0, 6/0

By-Pass Doors: 4/0, 5/0, 6/0

*Custom sizes available upon request.*

# Raised Panel Doors

## CHARLESTON/ARLINGTON INTERIOR DOORS

C4-10  
A4-10

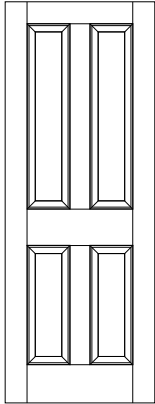

C4-11  
A4-11

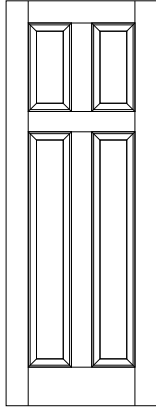

C4-12  
A4-12

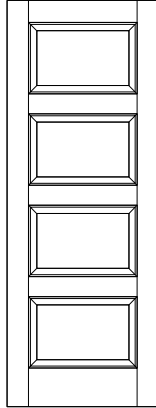

C5-10  
A5-10

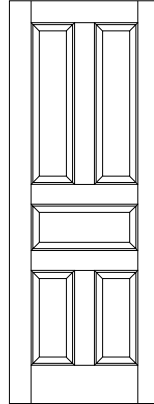

C5-11  
A5-11

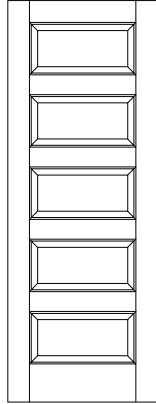

C6-10  
A6-10

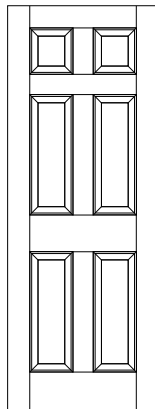

C6-11  
A6-11

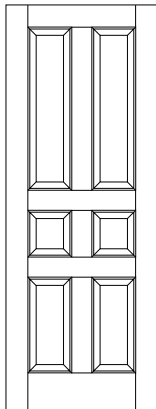

C6-12  
A6-12

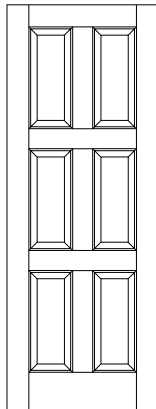

C6-13  
A6-13

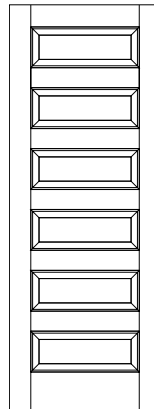

C8-10  
A8-10

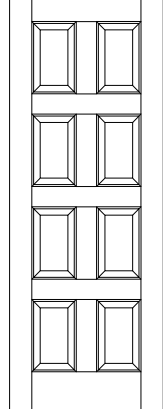

*Always refer to the Jamb Availability chart on page 11 for available jamb options.*

**For Finish, Hinge, Door Profile and Arch Option availabilities, see the General Information section.**

See pages 44-49 for sizing diagrams.

# Raised Panel Doors

## CHARLESTON/ARLINGTON "ROMAN ARCH" DOORS - 20 SERIES

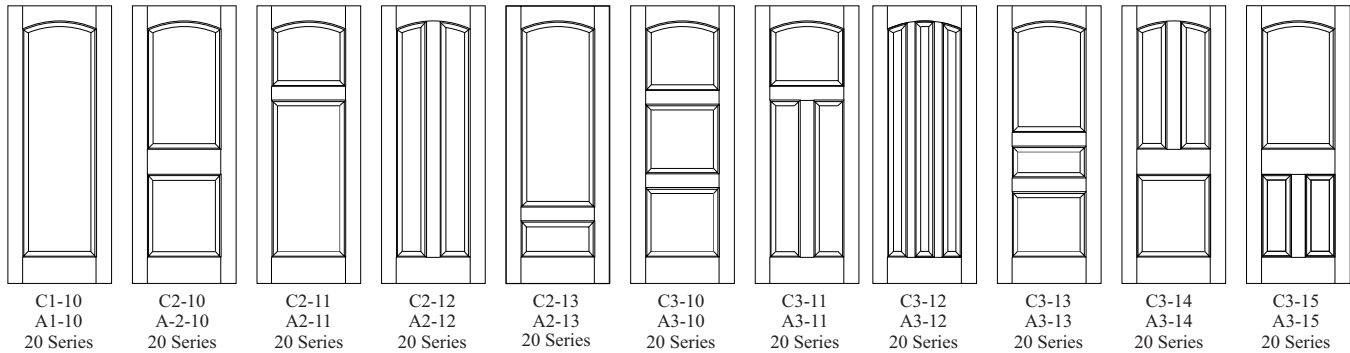

- ♦ See page 31 for sizing specs and panel layouts of "Roman Arch" Charleston/Arlington Doors.
- ♦ Refer to the Jamb Availability Chart on page 11 for available jamb options.

continued ... ➤

## CHARLESTON/ARLINGTON "CATHEDRAL ARCH" DOORS - 30 SERIES

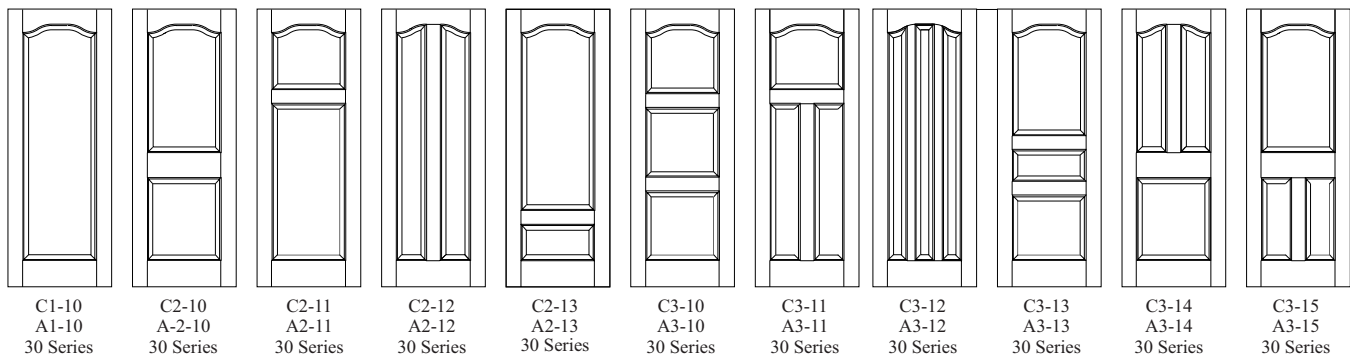

- ♦ See page 32 for sizing specs and panel layouts of "Cathedral Arch" Charleston/Arlington Doors. Please note that the smallest passage door available with a complete Cathedral Arch is a 1/10 door. Doors smaller than a 1/10 have a half-arch.
- ♦ Refer to the Jamb Availability Chart on page 11 for available jamb options.

continued ... ➤

## CHARLESTON/ARLINGTON "ARCH TOP" DOORS (EYEBROW) - 40 SERIES

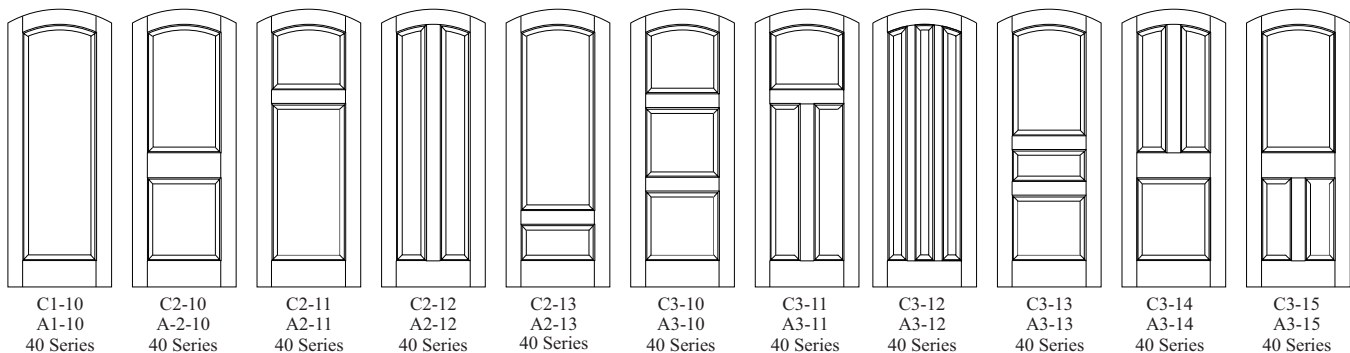

- ♦ See page 33 for sizing specs and panel layouts of "Arch Top" Charleston/Arlington Doors.
- ♦ Arch Top doors are available pre-hung in Solid Wood Jamb only.

continued ... ➤

# Raised Panel Doors

## CHARLESTON/ARLINGTON "ROMAN ARCH" DOORS - 20 SERIES



- ♦ See page 31 for sizing specs and panel layouts of "Roman Arch" Charleston/Arlington Doors.
- ♦ Refer to the Jamb Availability Chart on page 11 for available jamb options.

## CHARLESTON/ARLINGTON "CATHEDRAL ARCH" DOORS - 30 SERIES

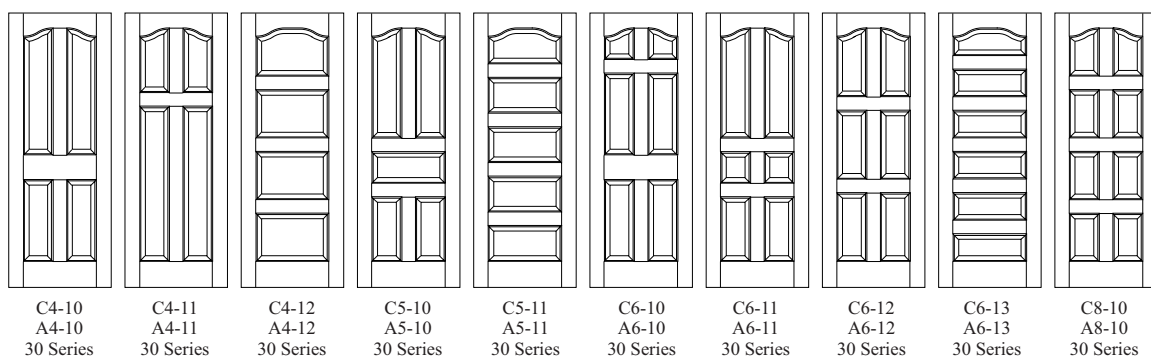

- ♦ See page 32 for sizing specs and panel layouts of "Cathedral Arch" Charleston/Arlington Doors. Please note that the smallest passage door available with a complete Cathedral Arch is a 1/10 door. Doors smaller than a 1/10 have a half-arch.
- ♦ Refer to the Jamb Availability Chart on page 11 for available jamb options.

## CHARLESTON/ARLINGTON "ARCH TOP" DOORS (EYEBROW) - 40 SERIES

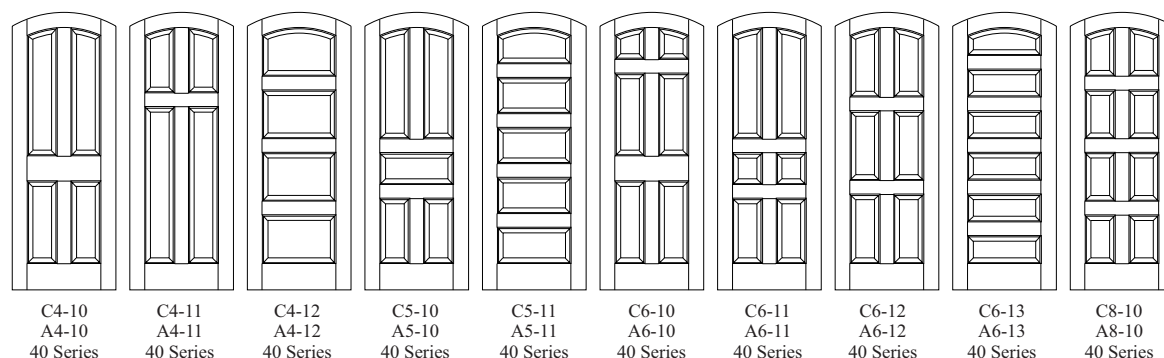

- ♦ See page 33 for sizing specs and panel layouts of "Arch Top" Charleston/Arlington Doors.
- ♦ Arch Top doors are available pre-hung in Solid Wood Jamb only.

# Raised Panel Doors

## "CHARLESTON/ARLINGTON" DOOR SIZING DIAGRAMS

ARROWS INDICATE GRAIN DIRECTION ON CHARLESTON DOORS.

### C1-10/A1-10

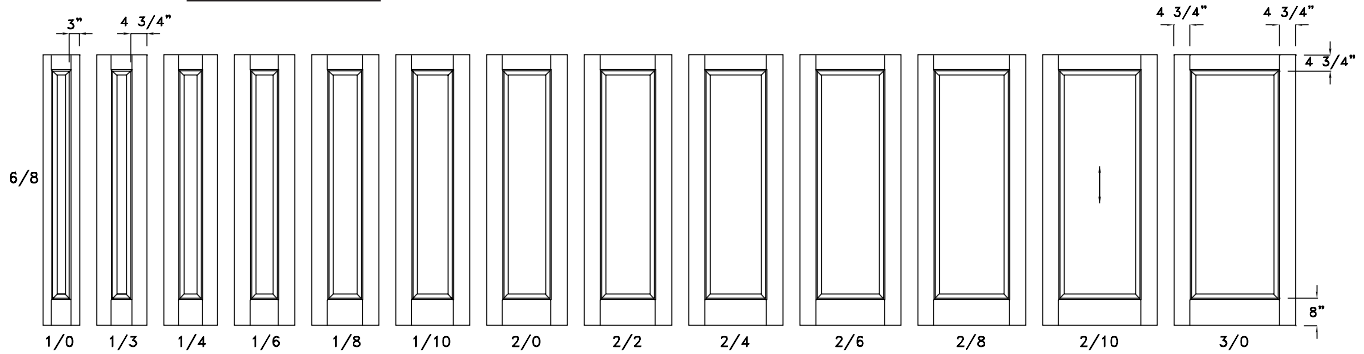

### C2-10/A2-10

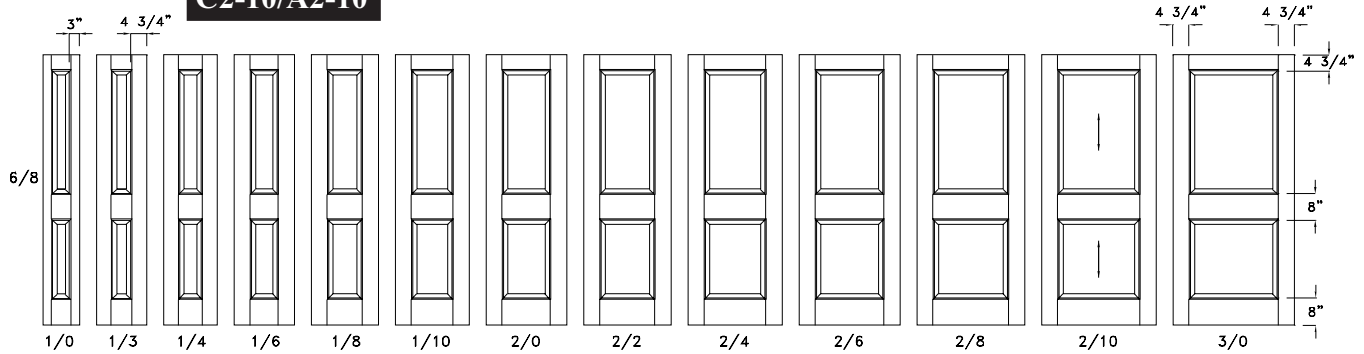

### C2-11/A2-11

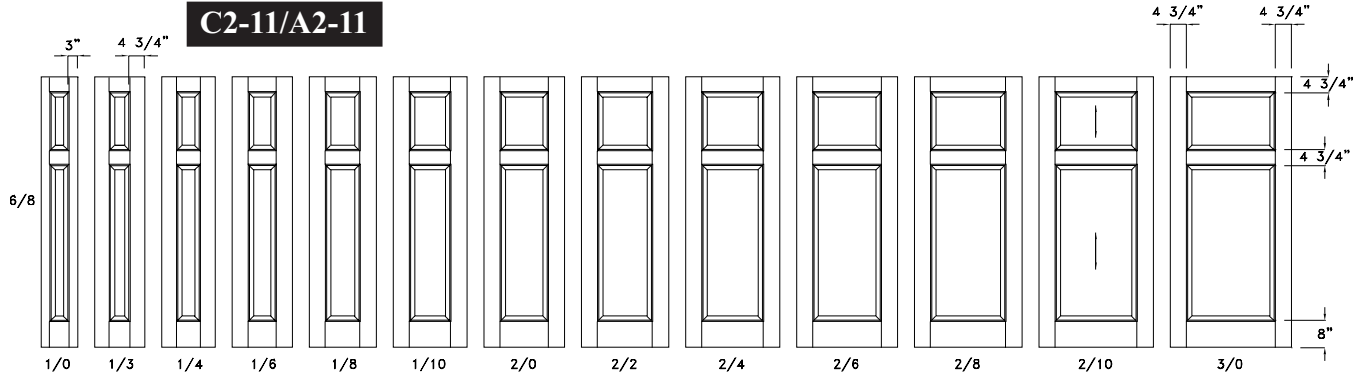

### C2-12/A2-12

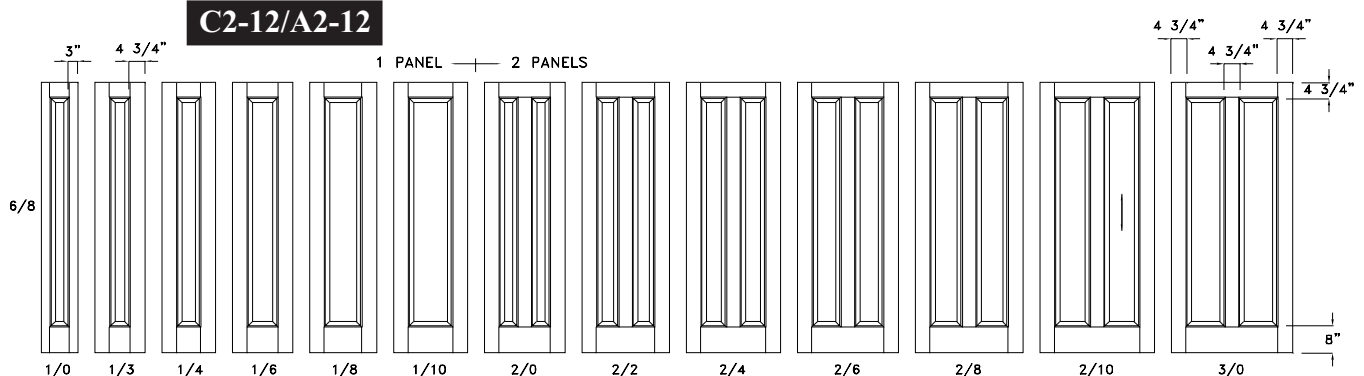



# Raised Panel Doors

## "CHARLESTON/ARLINGTON" DOOR SIZING DIAGRAMS

**C2-13/A2-13**

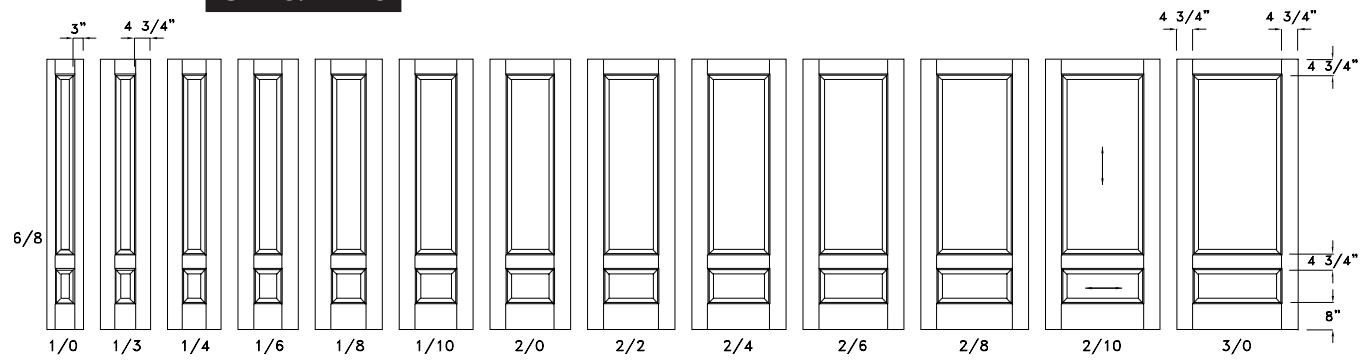

**C3-10/A3-10**

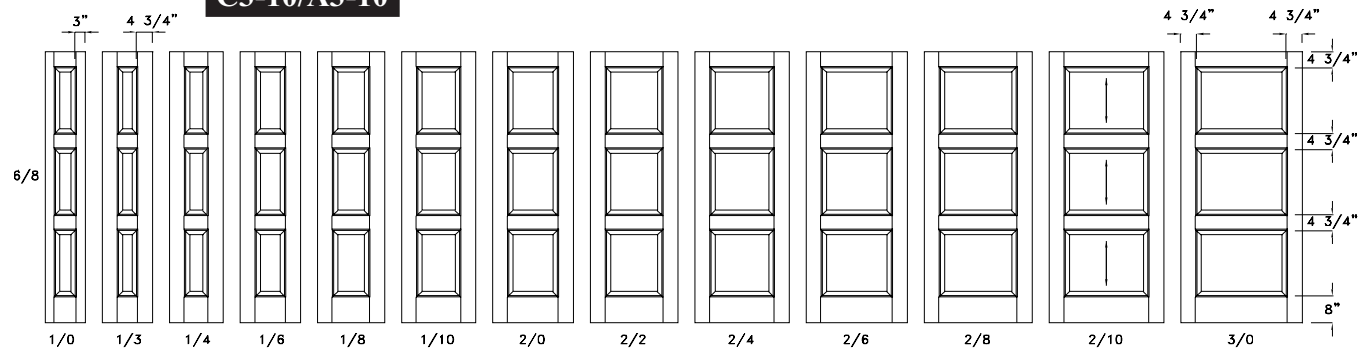

**C3-11/A3-11**

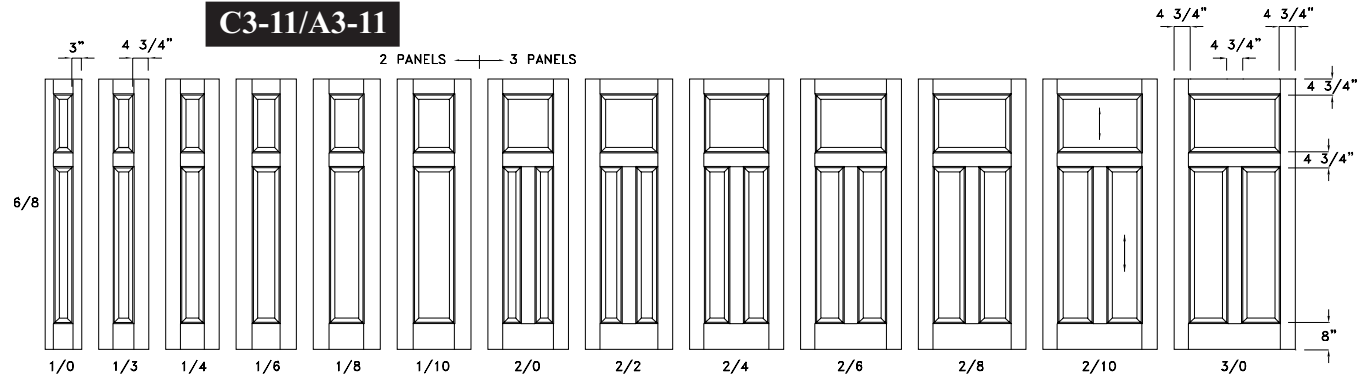

**C3-12/A3-12**

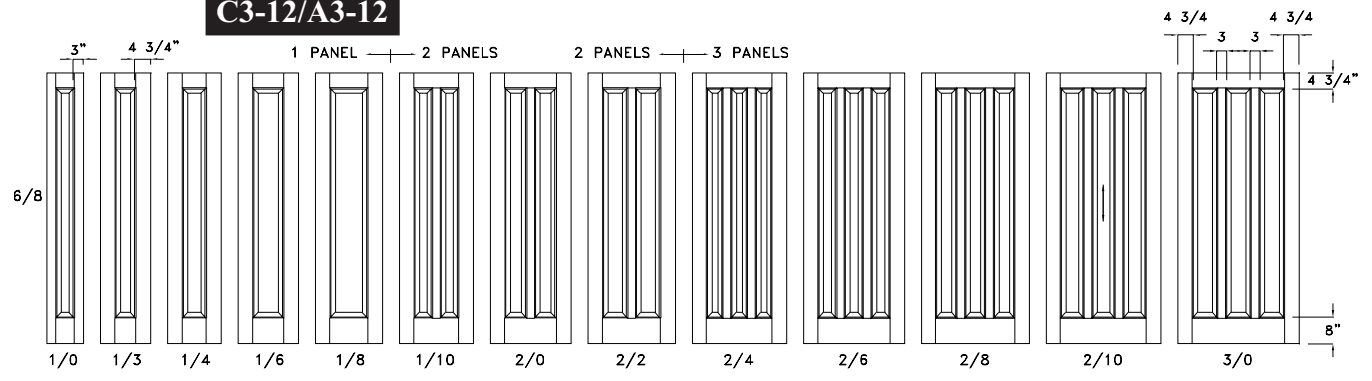

# Raised Panel Doors

## "CHARLESTON/ARLINGTON" DOOR SIZING DIAGRAMS

ARROWS INDICATE  
GRAIN DIRECTION  
ON CHARLESTON  
DOORS.

### C3-13/A3-13

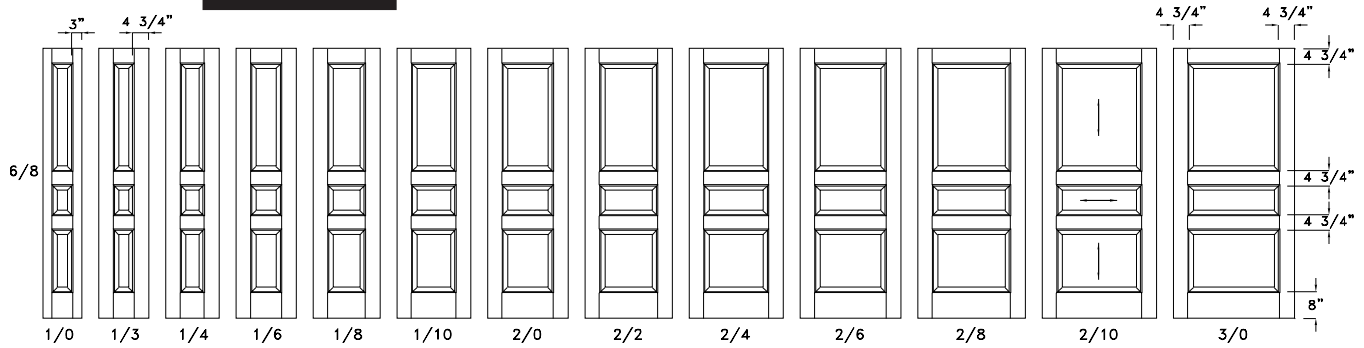

### C3-14/A3-14

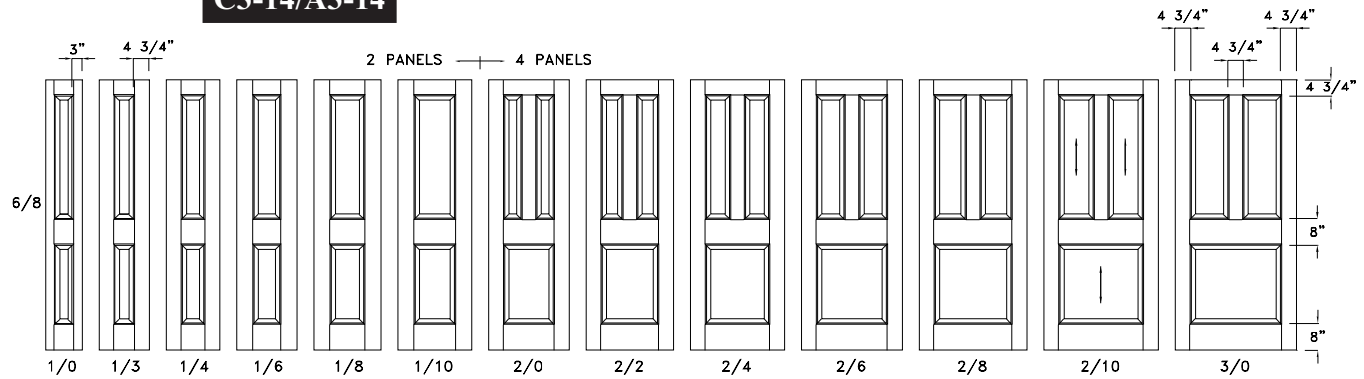

### C3-15/A3-15

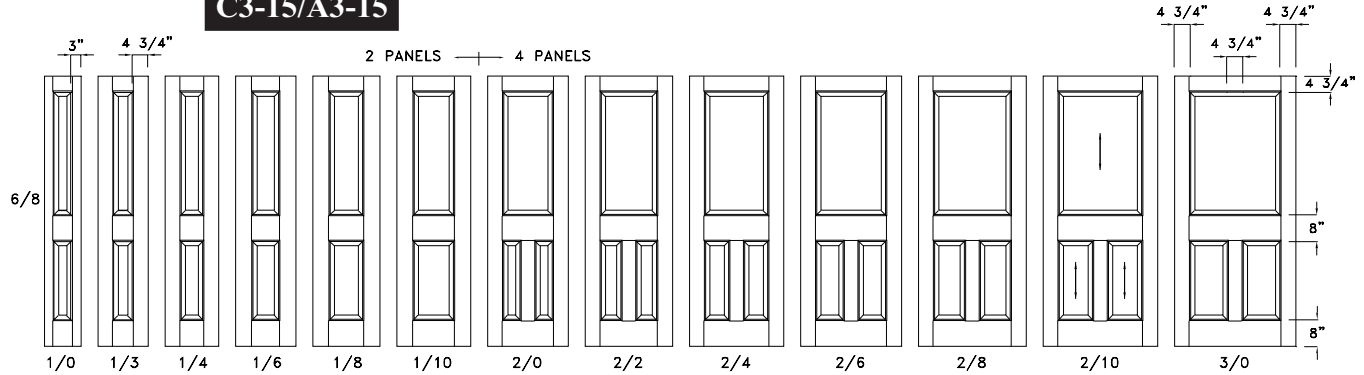

### C4-10/A4-10

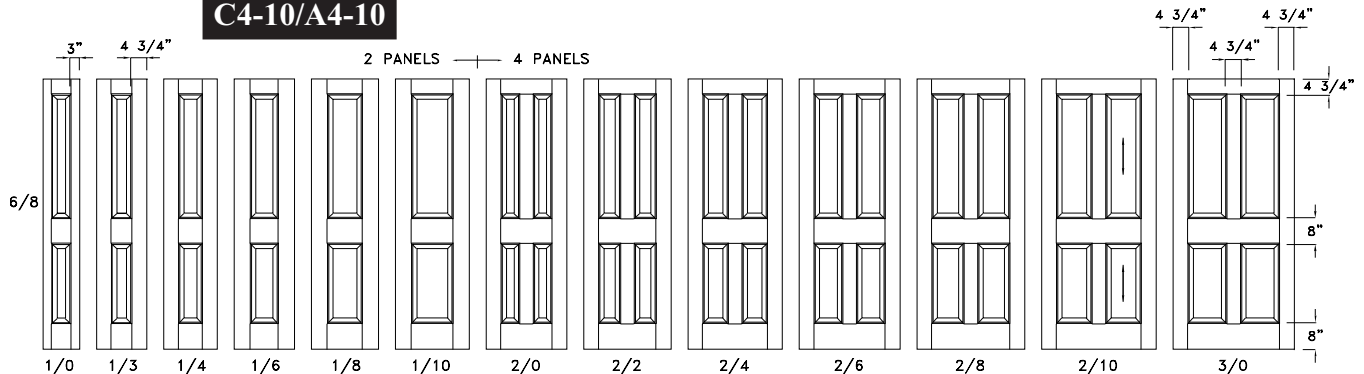

# Raised Panel Doors

## "CHARLESTON/ARLINGTON" DOOR SIZING DIAGRAMS

### C4-11/A4-11

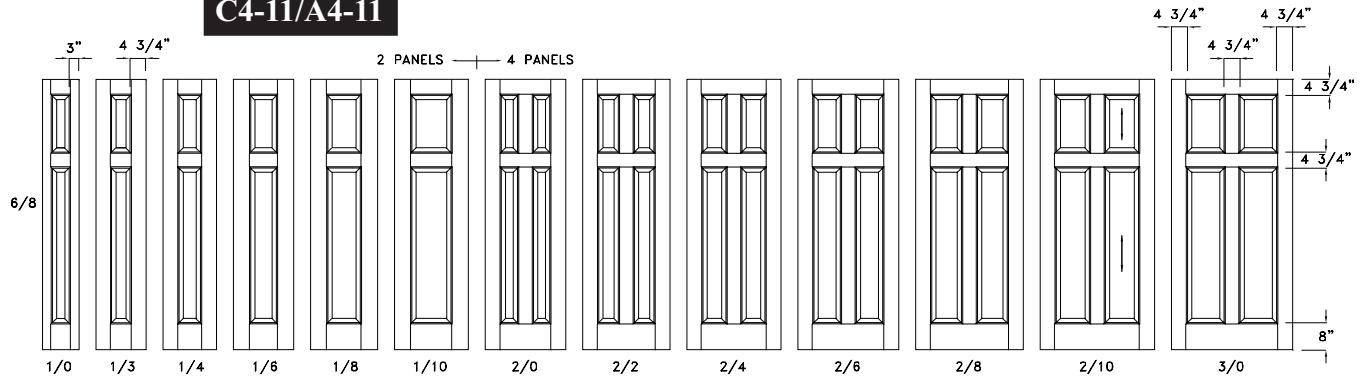

### C4-12/A4-12

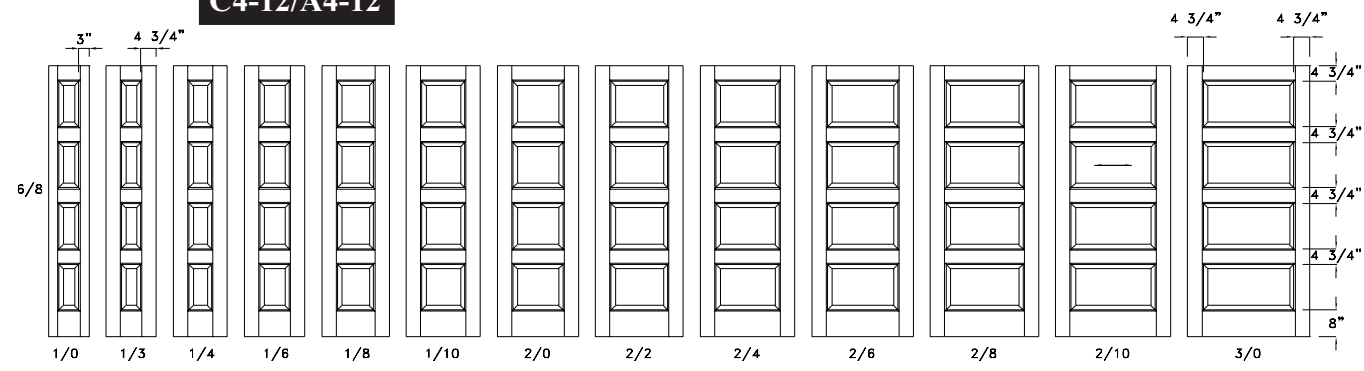

### C5-10/A5-10

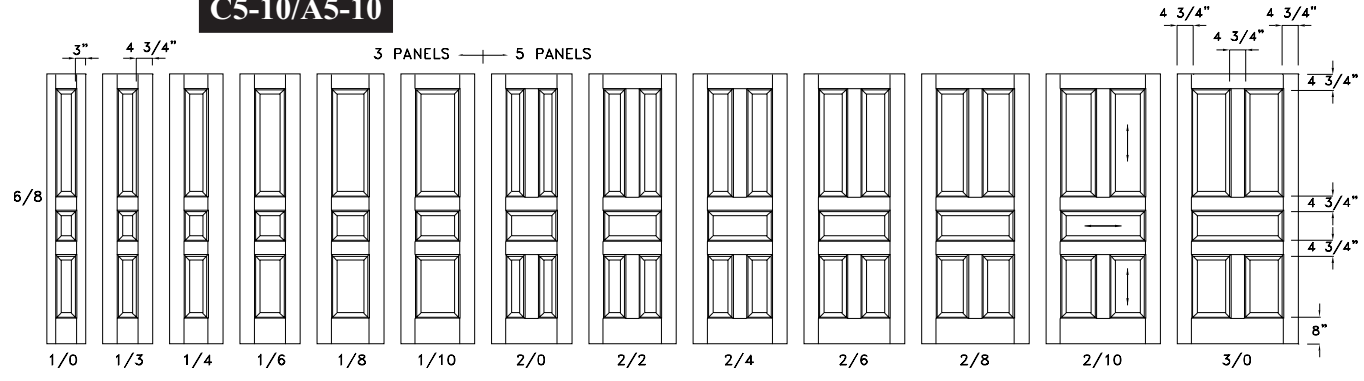

### C5-11/A5-11

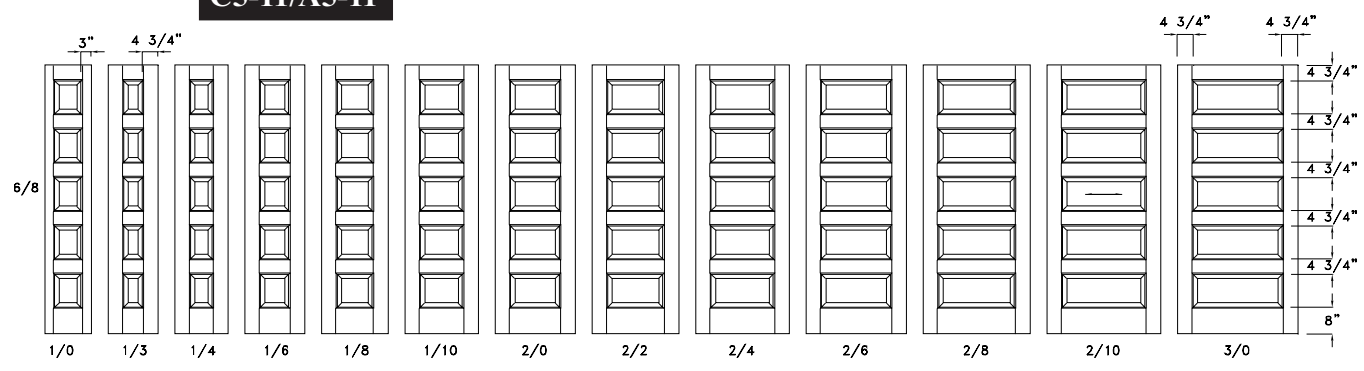

# Raised Panel Doors

## "CHARLESTON/ARLINGTON" DOOR SIZING DIAGRAMS

ARROWS INDICATE GRAIN DIRECTION ON CHARLESTON DOORS.

### C6-10/A6-10

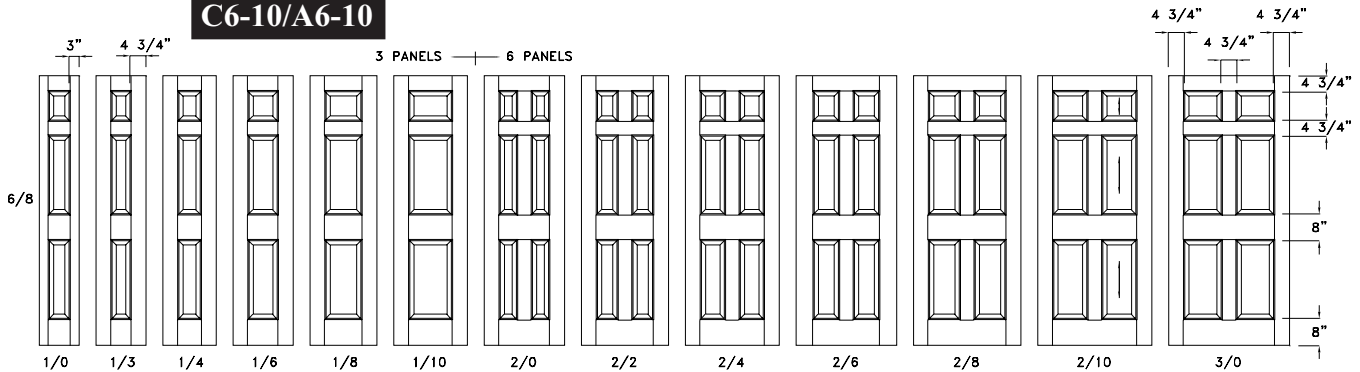

### C6-11/A6-11

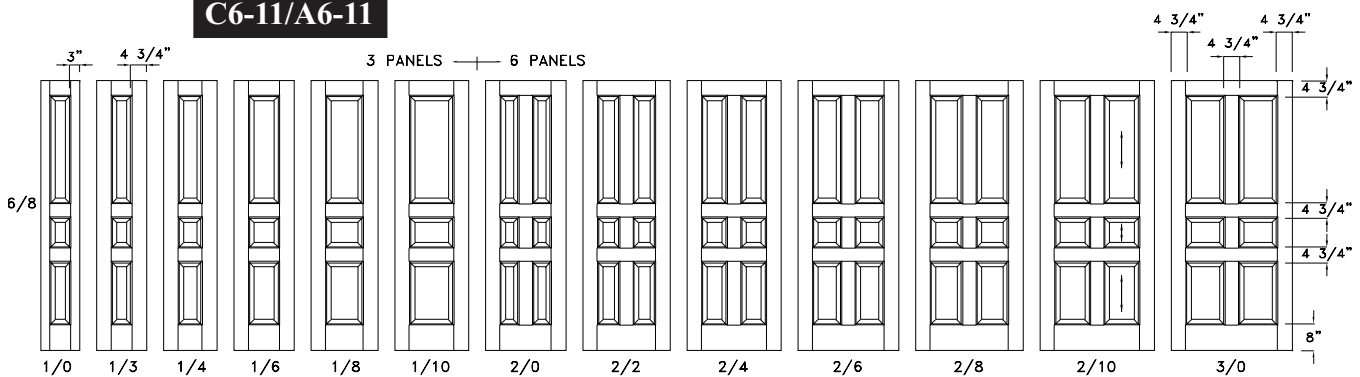

### C6-12/A6-12

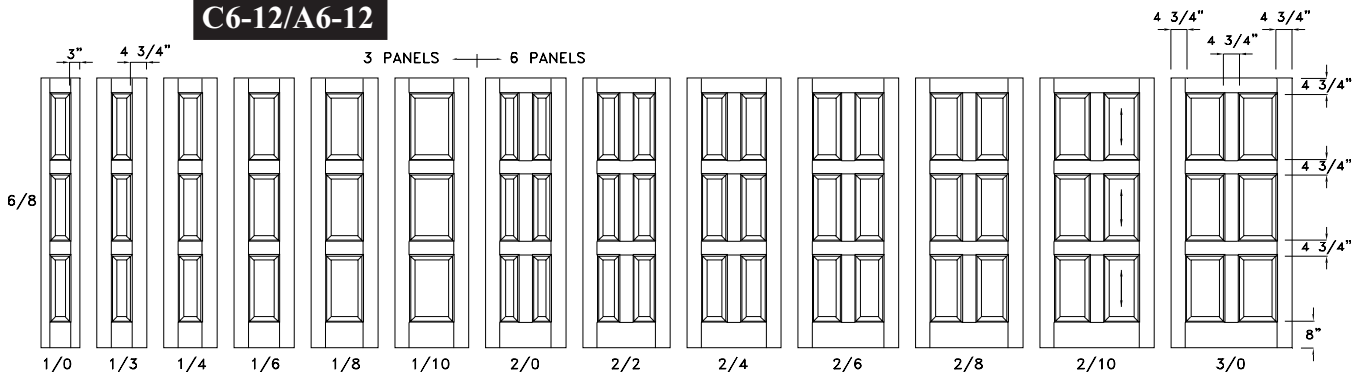

### C6-13/A6-13

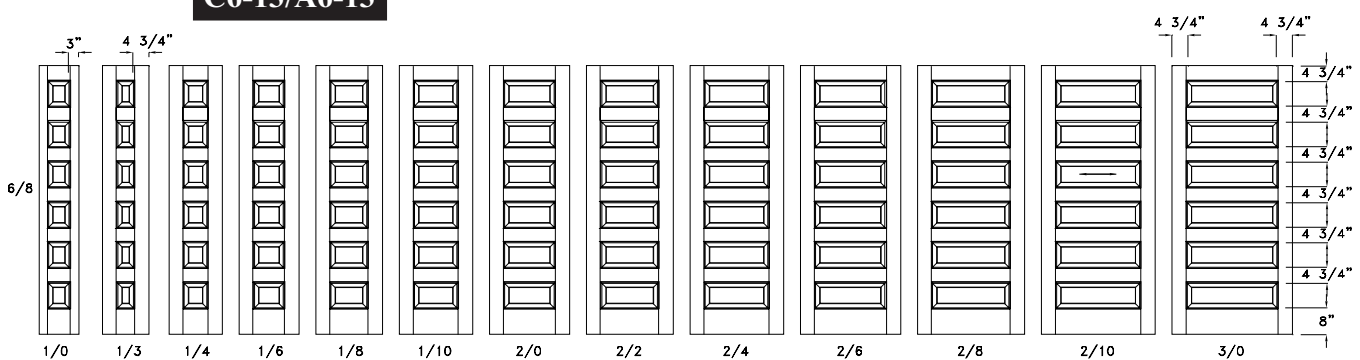

# Raised Panel Doors

## "CHARLESTON/ARLINGTON" DOOR SIZING DIAGRAMS

**C8-10/A8-10**

